

100G QSFP28 to QSFP28 Passive Direct Copper Cables

ND-P7D30-XXX

1. Applications

- 100 Gigabit Ethernet
- Fiber Channel over Ethernet
- Data storage and communication industry
- Switch/router/HBA
- Enterprise network
- SAN
- Data Center Network



2. Features

- QSFP28 conforms to the Small Form Factor SFF-8665
- 4-Channel Full-Duplex Passive Copper Cable Transceiver
- Support for multi-gigabit data rates :25.78Gb/s (per channel)
- Maximum aggregate data rate: 100Gb/s (4 x 25.78Gb/s)
- Copper link length up to 3m (passive limiting)
- High-Density QSFP 38-PIN Connector
- Power Supply :+3.3V
- Low power consumption: 0.02 W (typ.)
- I2C based two-wire serial interface for EEPROM signature which can be customized
- Temperature Range: 0~ 70 °C
- ROHS Compliant

3. Description

NEM Engine's 100G QSFP28 Passive Copper Cables(ND-P7D30-XXX) are high performance, cost effective I/O solutions for 100G LAN, HPC and SAN applications. The QSFP28 passive copper cables are compliant with SFF-8436. It is offer a low power consumption, short reach interconnect applications. The cable each lane is capable of transmitting data at rates up to 25.78Gb/s, providing an aggregated rate of 100Gb/s.

4. standard

- IEEE 802.3bj
- InfiniBand EDR
- QSFP28 MSA
- ROHS Compliant

5. Performance Specifications

5.1. Absolute Maximum Ratings

These values represent the damage threshold of the module. Stress in excess of any of the individual Absolute Maximum Ratings can cause immediate catastrophic damage to the module even if all other parameters are within Recommended Operating Conditions.

Table.1 Absolute maximum ratings

Parameter	Symbol	Min	Max	Unit
Maximum Supply Voltage	Vcc	0	3.6	V
Storage Temperature	Ts	-40	85	°C
Relative Humidity	RH	5	95	%

5.2. Recommended Operating Conditions

Table.2 Recommended Operating Conditions

Parameter	Symbol	Min	Typical	Max	Unit
Operating Case Temperature	Standard Tc	0	25	70	°C
Storage Temperature	Ts	0		70	°C
Relative Humidity	RH	5		95	%
Data Rate				25.78	Gbps
Power Dissipation	PD			0.02	W

5.3. Product Characteristics

Table.3 Product Characteristics

Parameter	Symbol	Min	Typical	Max	Unit	Note
Differential Impedance	Rin,p-p	90	100	110	Ω	
Insertion loss	SDD21	8		22.48	dB	At 12.8906 GHz
Differential Return Loss	SDD11	12.45		See1	dB	At 0.05 to 4.1 GHz
	SDD22	3.12		See2	dB	At 4.1 to 19 GHz
Common-mode to common-mode output return loss	SDD11 SDD22	2			dB	At 0.2 to 19 GHz
Differential to common-mode return loss	SDD11	12		See3	dB	At 0.01 to 12.89 GHz
	SDD22	10.58		See4		At 12.89 to 19 GHz
Differential to common-mode Conversion Loss	SCD21-IL	10		See5	dB	At 0.01 to 12.89 GHz
						At 12.89 to 15.7 GHz
		6.3				At 15.7 to 19 GHz
Channel Operating Margin	COM	3			dB	

Notes:

- 1.Reflection Coefficient given by equation $SDD11(dB) < 16.5 - 2 * \sqrt{f}$, with f in GHz
- 2.Reflection Coefficient given by equation $SDD11(dB) < 10.66 - 14 * \log_{10}(f/5.5)$, with f in GHz
- 3.Reflection Coefficient given by equation $SDD11(dB) < 22 - (20/25.78) * f$, with f in GHz
- 4.Reflection Coefficient given by equation $SDD11(dB) < 15 - (6/25.78) * f$, with f in GHz
- 5.Reflection Coefficient given by equation $SDD21(dB) < 27 - (29/22) * f$, with f in GHz

5.4. Pin Definitions

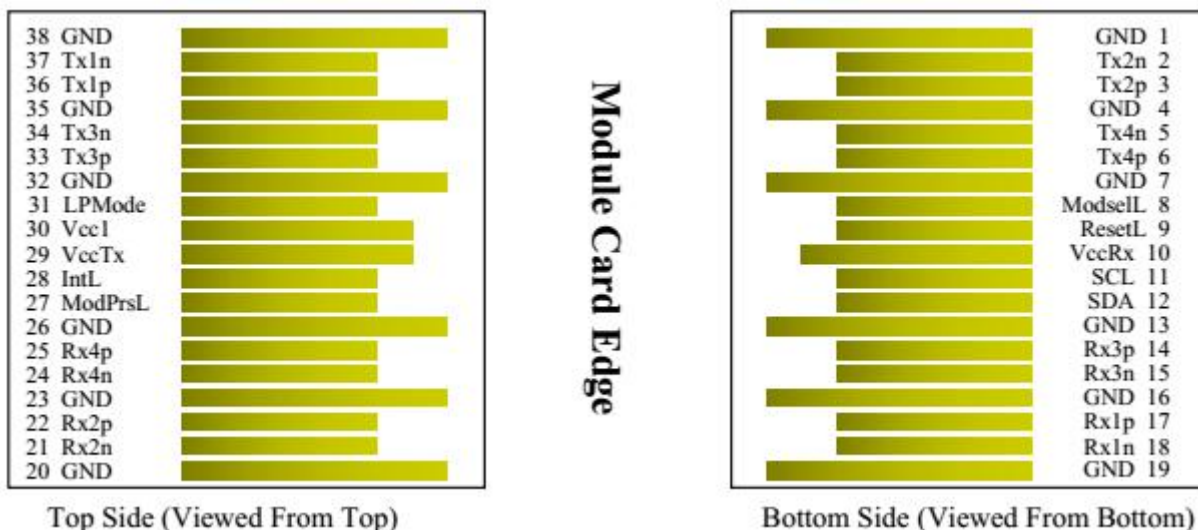

Table.4 QSFP Pin Definitions

Pin number	Logic	Symbol	Signal	Description
1		GND	Signal Ground	Ground
2	CML-I	Tx2n	Tx2n	Transmitter Inverted Date Input.AC coupled
3	CML-I	Tx2p	Tx2p	Transmitter Non_Inverted Date Input.AC coupled
4		GND	Signal Ground	Ground
5	CML-I	Tx4n	Tx4n	Transmitter Inverted Date Input.AC coupled
6	CML-I	Tx4p	Tx4p	Transmitter Non_Inverted Date Input.AC coupled
7		GND	Signal Ground	Ground
8	LVTTL-I	ModSelL	ModSelL	Module Select pin.Selected when held low by the host.
9	LVTTL-I	ResetL	LPMoDe_Reset	Module Reset.A"low" pulse induces a reset on the module.
10		Vcc Rx	Vcc Rx	+3.3V Power Supply Receiver
11	LVC MOS-I/O	SCL	SCL	2-wire serial interface
12	LVC MOS-I/O	SDA	SDA	
13		GND	Signal Ground	Ground
14	CML-O	Rx3p	Rx3p	Receiver Non_Inverted Date Input.AC coupled
15	CML-O	Rx3n	Rx3n	Receiver Inverted Date Input.AC coupled
16		GND	Signal Ground	Ground
17	CML-O	Rx1p	Rx1p	Receiver Non_Inverted Date Input.AC coupled
18	CML-O	Rx1n	Rx1n	Receiver Inverted Date Input.AC coupled
19		GND	Signal Ground	Ground
20		GND	Signal Ground	Ground
21	CML-O	Rx2n	Rx2n	Receiver Inverted Date Input.AC coupled
22	CML-O	Rx2p	Rx2p	Receiver Non_Inverted Date Input.AC coupled
23		GND	Signal Ground	Ground
24	CML-O	Rx4n	Rx4n	Receiver Inverted Date Input.AC coupled
25	CML-O	Rx4p	Rx4p	Receiver Non_Inverted Date Input.AC coupled
26		GND	Signal Ground	Ground
27	LVTTL-O	ModPrsL	ModPrsL	Module Present pin.Internally grounded inside the module.
28	LVTTL-O	IntL	IntL	Interrupt by the QSFP module."Low"indicates an Alarm/Warning.
29		Vcc Tx	Vcc Tx	+3.3V Power Supply Transmitter
30		Vccl	Vccl	+3.3V Power Supply

Shenzhen NEM Engine Technology Co., Ltd.

Tel: 0086-400-966-4008

Fax: 0086-0755-86152561

E-mail: info@nemengine.com

Web: www.nemengine.com

31	LVTTL-I	LPMODE	LPMODE	Low Power Mode
32		GND	Signal Ground	Ground
33	CML-I	Tx3p	Tx3p	Transmitter Non_Inverted Date Input.AC coupled
34	CML-I	Tx3n	Tx3n	Transmitter Inverted Date Input.AC coupled
35		GND	Signal Ground	Ground
36	CML-I	Tx1p	Tx1p	Transmitter Non_Inverted Date Input.AC coupled
37	CML-I	Tx1n	Tx1n	Transmitter Inverted Date Input.AC coupled
38		GND	Signal Ground	Ground
Housing			Chassis Ground	

5.5. Mechanical Dimensions

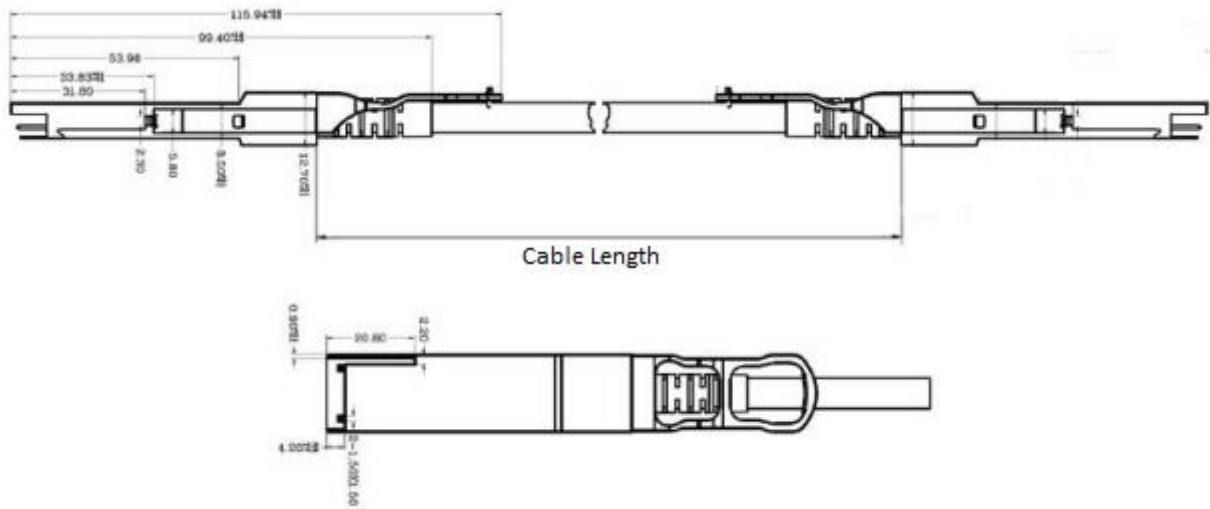

Diagram of Mechanical Dimensions

6. Application Cautions

6.1. ESD

This transceiver is specified as ESD threshold 1kV for high speed pins and 2kV for all other electrical input pins, tested per MIL-STD-883, Method 3015.4 /JESD22-A114-A (HBM). However, normal ESD precautions are still required during the handling of this module. This transceiver is shipped in ESD protective packaging. It should be removed from the packaging and handled only in an ESD protected environment.

6.2. LASER SAFTY

This is a Class 1 Laser Product according to IEC 60825-1:1993:+A1:1997+A2:2001. This product complies with 21 CFR 1040.10 and 1040.11 except for deviations pursuant to Laser Notice No. 50, dated (July 26, 2001)

6.3. Important Notice

Important Notice:

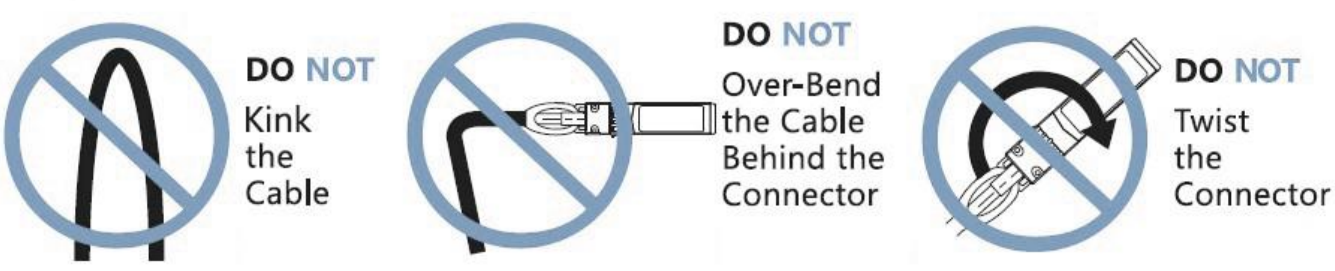

ANTISTATIC  **FRAGILE**

Note:

- 1)Copper type maximum length recommended at 15 meters;
- 2)Various cable lengths available for all types;
- 3)Latch/tab available”on top”or”bottom”position.

7. Order Information

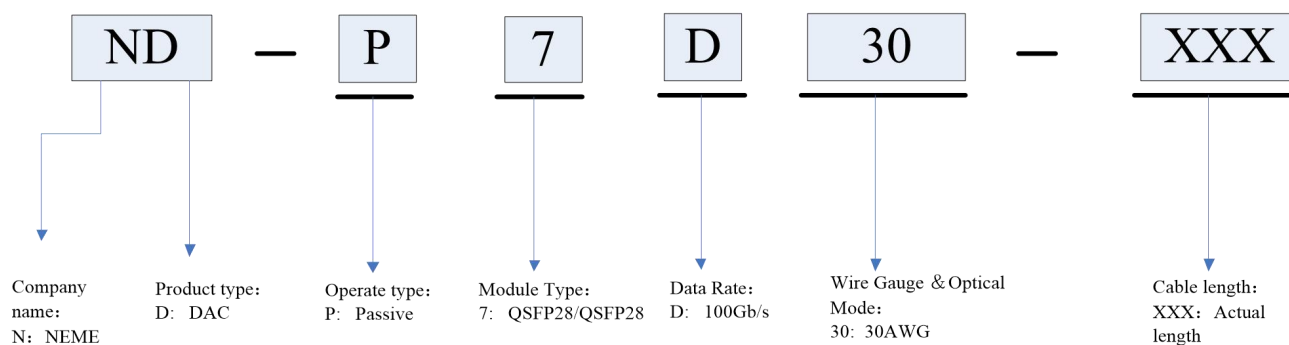

Further Information

For further information, please contact NEME.

Tel: 0086-400-966-4008

Fax: 0086-0755-86152561

Web: www.nemengine.com

Add: 3/F, 20th Bldg. Guangqian Ind Zone. No.3 Longzhu Rd. Nanshan Dist. S.Z City, CHINA.

Shenzhen NEM Engine Technology Co., Ltd.

Tel: 0086-400-966-4008

Fax: 0086-0755-86152561

E-mail: info@nemengine.com

Web: www.nemengine.com