

40G QSFP+ to QSFP+ Passive Direct Copper Cables

ND-P4CXX-XXX

1. Applications

- 10 Gigabit Ethernet 4
- 0 Gigabit Ethernet
- InfiniBand4x SDR, DDR, QDR
- 2, 4, 8, 10 Gigabit Fiber Channel
- Fiber Channel over Ethernet SAS,Servers,Hubs,Switches,Routers
- SFP+ DAC, 40G DAC, DAC Cable



2. Features

- QSFP+ conforms to the Small Form Factor SFF-8436
- 4-Channel Full-Duplex Passive Copper Cable Transceiver
- Support for multi-gigabit data rates :1 Gb/s - 10 Gb/s (per channel)
- Maximum aggregate data rate: 40 Gb/s (4 x 10Gb/s)
- Copper link length up to 5m (passive limiting)
- High-Density QSFP 38-PIN Connector
- Power Supply :+3.3V
- Low power consumption: 0.02 W (typ.)
- I2C based two-wire serial interface for EEPROM signature which can be customized
- Temperature Range: 0~ 70 °C

3. Description

NEM Engine's 40G QSFP+ Passive Copper Cables(ND-P4CXX-XXX) are high performance, cost effective I/O solutions for 40G LAN, HPC and SAN applications. The QSFP+ passive copper cables are compliant with SFF-8436, QSFP+ MSA and IEEE P802.3ba 40GBASE-CR4. It is offer a low power consumption, short reach interconnect applications. The cable each lane is capable of transmitting data at rates up to 10Gb/s, providing an aggregated rate of 40Gb/s.

NEM Engine's 40G QSFP+ Passive Copper Cables are customized for an ultra-high performance, cost effective cable solution in 40-Gigabit speed applications including switched fabric I/O, switches, routers, data storage arrays, and high performance computer (HPC) clusters.

4. standard

- 10 Gigabit Ethernet 4
- 10 Gigabit Ethernet
- InfiniBand4x SDR, DDR, QDR
- 2, 4, 8, 10 Gigabit Fiber Channel
- Fiber Channel over Ethernet SAS,Servers,Hubs,Switches,Routers
- SFP+ DAC, 40G DAC, DAC Cable

5. Performance Specifications

5.1. Absolute Maximum Ratings

These values represent the damage threshold of the module. Stress in excess of any of the individual Absolute Maximum Ratings can cause immediate catastrophic damage to the module even if all other parameters are within Recommended Operating Conditions.

Table.1 Absolute maximum ratings

Parameter	Symbol	Min	Max	Unit
Maximum Supply Voltage	Vcc	0	3.6	V
Storage Temperature	Ts	-40	85	°C
Relative Humidity	RH	5	95	%

5.2. Recommended Operating Conditions

Table.2 Recommended Operating Conditions

Parameter	Symbol	Min	Typical	Max	Unit
Operating Case Temperature	Standard Tc	0	25	70	°C
Storage Temperature	Ts	0		70	°C
Relative Humidity	RH	5		95	%
Data Rate			40		Gbps
Power Dissipation	PD			0.02	W

5.3. Product Characteristics

Table.3 Product Characteristics

Test Type	Test Item	Target		Reference
	Differential Impedence	100+/- 10ohm (Rise time of 50 ps (20 %-80 %))		IEEE Std.802.3ba
Electrical Characteristics	Differential Mode RL	Frequency(GHz) 0.1-1.0 1.0-4.1	SDD11 & SDD22(max) -10 -(12-2*sqrt(f))	Per table 10 of 1B Cable MOL.v 0.68
	Differential IL	Frequency 100MHz 200MHz 625MHz 1250MHz 1875MHz 2500MHz	SDD21(min) -8 -8 -8.5 -12.1 -14.7 -17	Ref table 43 of Infiniband Architecture Spec, V2
	NEXT	≥26dB @ 10MHz to 5.0GHz		/
	Intra-Pair Skew	≤100 ps(TDT Method) Rise time of 35 ps		(20 %- 80 %)
	Intra-Pair Skew	≤400 ps(TDT Method) Rise time of 35 ps		(20%~80 %)
Environmental Characteristics	Operating Temperature	-40~85°C		Cable operating temp. range
	Thermal Shock	No evidence of physical damage		EIA-364-32 Test
	Cyclic Temp. & Humidity	No evidence of physical damage		EIA-364-31 Method III, Test Cond A
	Salt spray	48 hours salt spraying after shell corrosive area less than 5%		EIA-364-26
	Temperature Life	Performance meets the specification requirement		EIA-364-17, Method A, Test Cond 3 at 105°±2° C
Mechanical Characteristics	Mechanical Vibration	Performance meets the specification requirement		EIA-364-28E.11 TC-VII, Test Cond. D 15minutes in X,Y,Z axis.
	Cable Flex	Performance meets the specification requirement		EIA-444-1B
	Mechanical Shock	Performance meets the specification requirement		EIA-364-27B, TG-G. 3 times in 6 directions, 100g, 6ms
	Cable plug Insertion	40N Max.		Per QSFP MSA Rev 1.0
	Cable plug extraction	30N Max.		Per QSFP MSA Rev 1.0.
	Latch retention force	50N Min. No evidence of physical damage		EIA-364-13
	Durability	50 Time. No evidence of physical damage		EIA-364-09; perform plug&unplug cycles

5.4. Pin Definitions

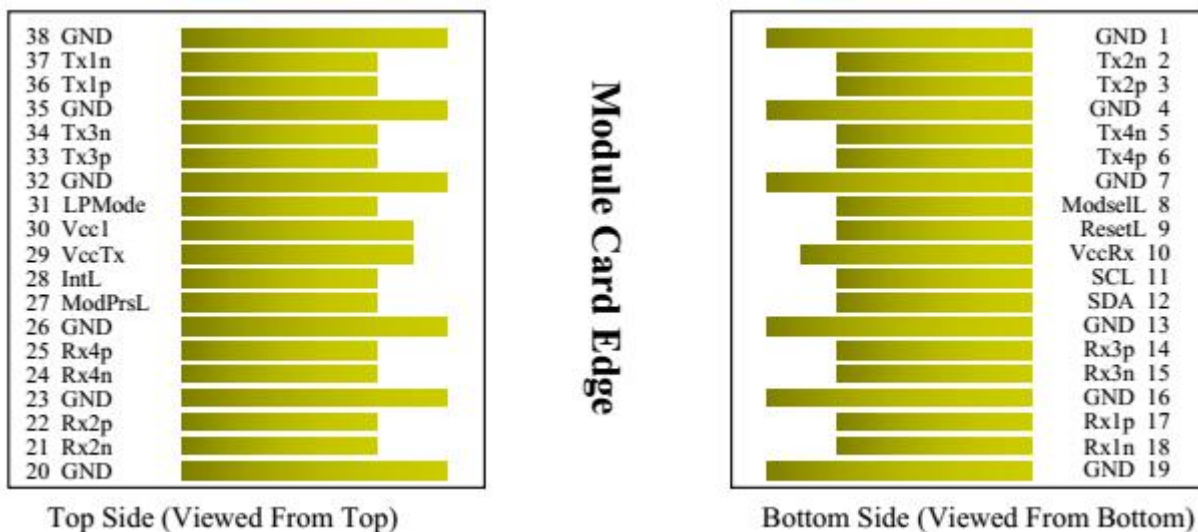

Table.4 QSFP Pin Definitions

Pin number	Logic	Symbol	Signal	Description
1		GND	Signal Ground	Ground
2	CML-I	Tx2n	Tx2n	Transmitter Inverted Date Input.AC coupled
3	CML-I	Tx2p	Tx2p	Transmitter Non_Inverted Date Input.AC coupled
4		GND	Signal Ground	Ground
5	CML-I	Tx4n	Tx4n	Transmitter Inverted Date Input.AC coupled
6	CML-I	Tx4p	Tx4p	Transmitter Non_Inverted Date Input.AC coupled
7		GND	Signal Ground	Ground
8	LVTTL-I	ModSelL	ModSelL	Module Select pin.Selected when held low by the host.
9	LVTTL-I	ResetL	LPMode_Reset	Module Reset.A"low" pulse induces a reset on the module.
10		Vcc Rx	Vcc Rx	+3.3V Power Supply Receiver
11	LVCMS-I/O	SCL	SCL	2-wire serial interface
12	LVCMS-I/O	SDA	SDA	
13		GND	Signal Ground	Ground
14	CML-O	Rx3p	Rx3p	Receiver Non_Inverted Date Input.AC coupled
15	CML-O	Rx3n	Rx3n	Receiver Inverted Date Input.AC coupled
16		GND	Signal Ground	Ground
17	CML-O	Rx1p	Rx1p	Receiver Non_Inverted Date Input.AC coupled
18	CML-O	Rx1n	Rx1n	Receiver Inverted Date Input.AC coupled
19		GND	Signal Ground	Ground
20		GND	Signal Ground	Ground
21	CML-O	Rx2n	Rx2n	Receiver Inverted Date Input.AC coupled
22	CML-O	Rx2p	Rx2p	Receiver Non_Inverted Date Input.AC coupled
23		GND	Signal Ground	Ground
24	CML-O	Rx4n	Rx4n	Receiver Inverted Date Input.AC coupled
25	CML-O	Rx4p	Rx4p	Receiver Non_Inverted Date Input.AC coupled
26		GND	Signal Ground	Ground
27	LVTTL-O	ModPrsL	ModPrsL	Module Present pin.Internally grounded inside the module.
28	LVTTL-O	IntL	IntL	Interrupt by the QSFP module."Low"indicates an Alarm/Warning.
29		Vcc Tx	Vcc Tx	+3.3V Power Supply Transmitter
30		Vccl	Vccl	+3.3V Power Supply

Shenzhen NEM Engine Technology Co., Ltd.

Tel: 0086-400-966-4008

Fax: 0086-0755-86152561

E-mail:info@nemengine.com

Web: www.nemengine.com

31	LVTTL-I	LPMODE	LPMODE	Low Power Mode
32		GND	Signal Ground	Ground
33	CML-I	Tx3p	Tx3p	Transmitter Non_Inverted Date Input.AC coupled
34	CML-I	Tx3n	Tx3n	Transmitter Inverted Date Input.AC coupled
35		GND	Signal Ground	Ground
36	CML-I	Tx1p	Tx1p	Transmitter Non_Inverted Date Input.AC coupled
37	CML-I	Tx1n	Tx1n	Transmitter Inverted Date Input.AC coupled
38		GND	Signal Ground	Ground
Housing			Chassis Ground	

5.5. Mechanical Dimensions

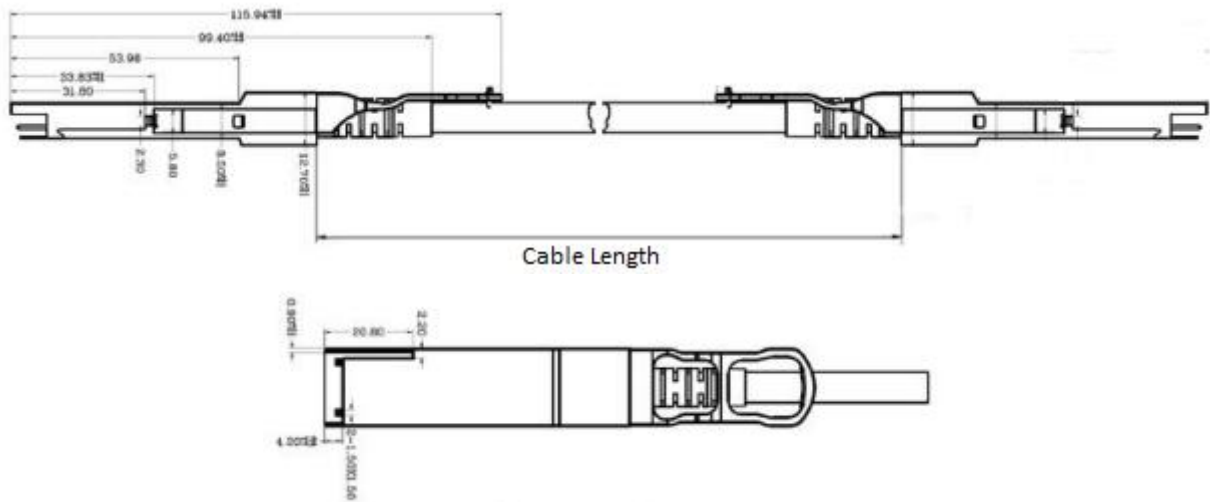

Diagram of Mechanical Dimensions

6. Application Cautions

6.1. ESD

This transceiver is specified as ESD threshold 1kV for high speed pins and 2kV for all other electrical input pins, tested per MIL-STD-883, Method 3015.4 /JESD22-A114-A (HBM). However, normal ESD precautions are still required during the handling of this module. This transceiver is shipped in ESD protective packaging. It should be removed from the packaging and handled only in an ESD protected environment.

6.2. LASER SAFTY

This is a Class 1 Laser Product according to IEC 60825-1:1993:+A1:1997+A2:2001. This product complies with 21 CFR 1040.10 and 1040.11 except for deviations pursuant to Laser Notice No. 50, dated (July 26, 2001)

6.3. Important Notice

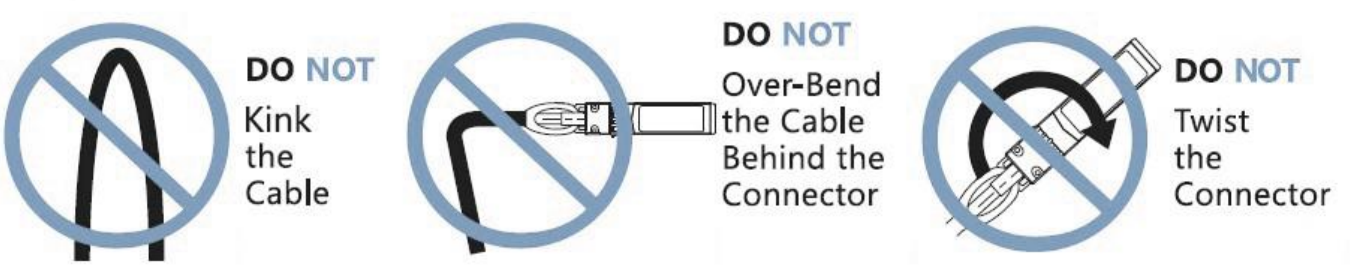

Important Notice:



DO NOT Kink the Cable

DO NOT Over-Bend the Cable Behind the Connector

DO NOT Twist the Connector

 **ANTISTATIC**  **FRAGILE**

Note:

- 1)Copper type maximum length recommended at 15 meters;
- 2)Various cable lengths available for all types;
- 3)Latch/tab available”on top”or”bottom”position.

7. Order Information

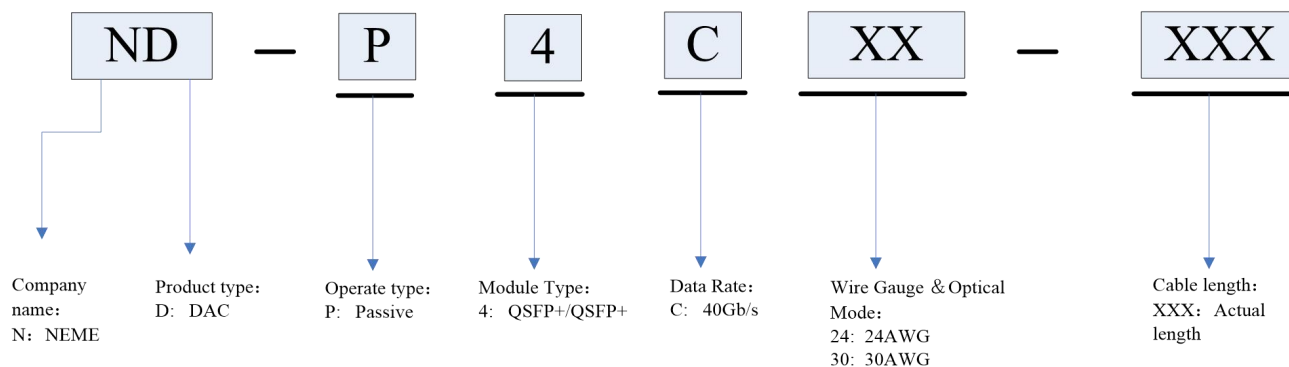

Further Information

For further information, please contact NEME.

Tel: 0086-400-966-4008

Fax: 0086-0755-86152561

Web: www.nemengine.com

Add: 3/F, 20th Bldg. Guangqian Ind Zone. No.3 Longzhu Rd. Nanshan Dist. S.Z City, CHINA.

Shenzhen NEM Engine Technology Co., Ltd.

Tel: 0086-400-966-4008

Fax: 0086-0755-86152561

E-mail: info@nemengine.com

Web: www.nemengine.com