

40Gbps QSFP+ to 4*SFP+ Active Optical Cable

NA-A5CMX-XXX

1. Applications

- Low-latency and high-speed interconnections for high performance computing(HPC)
- 40G Ethernet SR4
- Other high-throughput data transmission network
- Storage area Network(SAN)



2. Features

- QSFP+ to 4*SFP+ module
- QSFP+ Maximum Aggregate Data Rate 40Gbps
- 4*SFP+ Maximum Aggregate Data Rate 4*10Gbps
- QDR,DDR,SDR(Infiniband)
- Bi-directional parallel link
- 10Gb/s per lane,X4 channels
- Up to 100m
- Low profile connectors
- Low power consumption
- Bundle multi-mode fiber array
- 850nm VCSEL four array
- PIN diode four array
- Hot-Pluggable

Shenzhen NEM Engine Technology Co., Ltd.

Tel: 0086-400-966-4008

Fax: 0086-0755-86152561

E-mail: info@nemengine.com

Web: www.nemengine.com

- I2C management interface
- From 0 to 70 degree case temperature
- 3.3V power supply voltage
- Electrical 38-pin connector

3. Description

NEM Engine's NA-A5CMX-XXX series are active optical cables (AOC) that allows bi-directional 40Gbps to 10Gbps transmission suitable for high performance computing(HPC)clustering and other high-throughput data network, with advantages such as high speed, high density, low latency, low power consumption and light weight.

4. standard

- Compliant with IEEE 802.3ba-2010,Annex 86A for 40GBASE-SR4
- Compliant with InfiniBand EDR,FDR,QDR,DDR,SDR
- Compliant with QSFP MSA(SFF-8436)
- Compliant with SFP MSA(SFF-8431)
- RoHS Compliant:lead-free

5. Performance Specifications

5.1. Absolute Maximum Ratings

These values represent the damage threshold of the module. Stress in excess of any of the individual Absolute Maximum Ratings can cause immediate catastrophic damage to the module even if all other parameters are within Recommended Operating Conditions.

Table.1 Absolute maximum ratings

Parameter	Conditions	Min	Max	Units
Power supply voltage at 3.3V		-0.3	4.5	V
Voltage on I/O pads		-0.3	VDD+0.3	V
Differential Input Swing			1.5	Vpp
Storage temperature	Non-condensing	-40	85	Celsius
Powered case temperature range	Non-condensing	-5	70	Celsius
Relative Humidity		5	85	%
Static discharge voltage on high speed pins	Human body model		500	V
Static discharge voltage on other pins	Human body model		2000	V
Air discharge to QSFP case	EN61000-4-2 Criterion B Test		15	kV
Contact discharge to QSFP case	EN61000-4-2 Criterion B Test		8	kV

5.2. Recommended Operating Conditions

Table.2 Recommended Operating Conditions

Parameter	Conditions	Min	Typ.	Max	Units
Data rate per lane	8B/10B Coding, 64B/66B Coding	1	10.3125	10.5	Gbps
3.3V Supply Voltage		3.13	3.3	3.47	V
Power supply noise including ripples	1kHz to frequency of operation measured at VCC_HOST			50	mVpp
Case temperature		0	35	70	Celsius

5.3. Transmitter Specification (Electrical)

Table.3 QSFP Transceiver Specification (Electrical)

Parameter	Condition	Min	Typ.	Max	Units
Power Consumption	-	-	0.8	1	W
Supply Current	-	-	0.24	0.29	mA

Table.4 QSFP Transmitter Specification (Electrical)

Parameter	Test Point	Min	Max.	Units	Conditions
Single ended input voltage tolerance	TP1a	-0.3	4	V	Referred to TP1 signal common(Internally AC coupled)
Differential input voltage swing	TP1a	200	1600	mVpp	Peak to peak differential
AC common-mode input voltage tolerance	TP1a	15	-	mV	RMS
Differential input return loss	TP1	See IEEE 802.3ba 86A.4.1.1	-	dB	10MHz to 11.1GHz
Differential to common-mode input return loss	TP1	10	-	dB	10MHz to 11.1GHz
J2 jitter tolerance	TP1a	0.17	-	UI	
J9 jitter tolerance	TP1a	0.29	-	UI	
Data Dependent Pulse Width Shrinkage (DDPWS) tolerance	TP1a	0.07	-	UI	
Eye mask coordinates: X1, X2 Y1, Y2	TP1a	Specification values 0.11, 0.31 95, 350		UI mV	Hit ratio = 5×10^{-5} see Figure. 3(a)

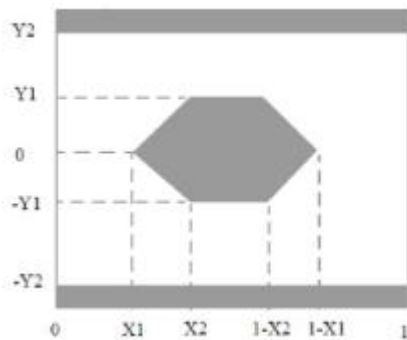

a) Transmitter electrical input eye mask

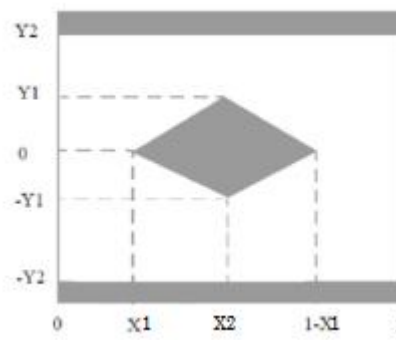

(b) Receiver electrical output eye mask

Figure 1. Eye Mask

5.4. Receiver Specification(Electrical)

Table.5 Receiver Specification (Electrical)

Parameter	Test Point	Min	Typ	Max.	Units	Conditions	
Single ended input voltage tolerance	TP4	-0.3	-	4	V	Referred to signal common (Internally AC coupled)	
AC common-mode input voltage	TP4	-	-	7.5	mV	RMS	
Differential Output swing (p-p)	TP4	-	320 (range 0)	-	mV	See details in the section "Memory Map", page03, byte 238-239.	
		-	420 (range 1)	-	mV		Default setting
		-	740 (range2)	-	mV		
		-	-	50	mV	Squelched state	
Termination mismatch at 1MHz	TP4	-	-	5	%		
Differential output return loss	TP4	See IEEE 802.3ba 86A.4.2.1		-	dB	10MHz to 11.1GHz	
Common-mode output return Loss	TP4	See IEEE 802.3ba 86A.4.2.2		-	dB	10MHz to 11.1GHz	
Output transition time, 20% to 80%	TP4	28	-	-	ps		
J2 jitter output	TP4	-	-	0.42	UI		
J9 jitter output	TP4	-	-	0.65	UI		
Eye mask coordinates: X1, X2 Y1,Y2	TP4	Specification values 0.29, 0.5 150, 425			UI mV	Hit ratio = 5 x 10 ⁻⁵ see Figure. 3(b)	

5.5.Test Point Definition

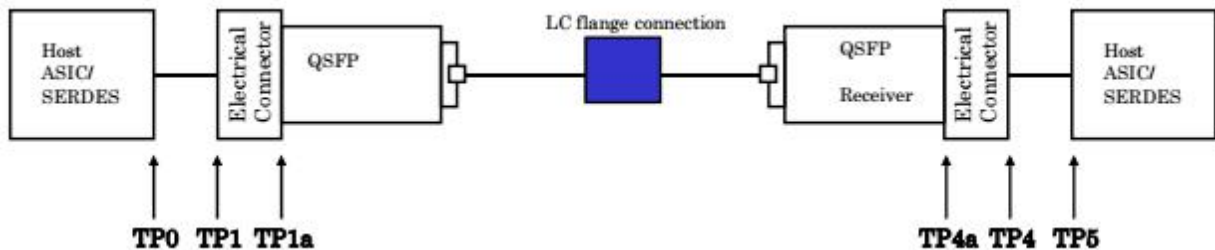

Figure 2. Test Point

5.6. Low Speed Electrical Specification

Table.6 Low Speed Electrical Specification

Parameter	Symbol	Min	Max.	Unit	Notes
ResetL,ModSelL	VIL	-0.3	0.8	V	I _{in} ≤125uA for 0V < V _{in} , V _{cc}
	VIH	2	VCC+0.3	V	
LPMODE					Not connected inside QSFP
ModPraL					Internally terminated to GND
IntL	VOL	0	0.4	V	IOL=2mA
	VOH	VCC-0.5	VCC+0.3	V	
SCL,SDA	VOL	0	0.4	V	IOL(max)=3mA
	VOH	VCC-0.5	VCC+0.3	V	
	VIL	-0.3	VCC*0.3	V	
	VIH	VCC*0.7	VCC+0.5	V	
Capacitance for SCL and SDA I/O Pin	Ci		14	pF	
Total bus capacitance load for SCL and SDA	Cb		100	pF	3.0kohm Pullup resistor,max
			200	pF	1.6kohm Pullup resistor,max

5.7. QSFP Transmitter Optical Specifications

Table.7 Transmitter Optical Specification

Parameter	Test Point	Min	Typ.	Max	Units	Conditions
Center wavelength	TP2	840	850	860	nm	
RMS spectral width	TP2			0.45	nm	Standard deviation
Average launch power	TP2	-2		4	dBm	Each lane
Optical Modulation Amplitude	TP2	-5.6		3	dBm	Each lane
Difference in launch power between any two lanes(OMA)	TP2			4	dB	
Peak power	TP2			0	dBm	Each lane
Launch power in OMA minus TDP	TP2	-6.5			dBm	Each lane
Extinction ratio	TP2	3			dB	
Optical return loss tolerance	TP2			12	dB	
Encircled flux	TP2	≥86% at 19um, ≤30% at 4.5um				Measured into type A1a.2 50um fiber in accordance with EN 61280-1-4

Eye mask coordinate: X1,X2,X3,Y1,Y2,Y3	TP2	Specification values 0.23,0.34,0.43 0.27,0.35,0.40	UI	Hit ratio= 5×10^{-5} see Figure.5
---	-----	--	----	---

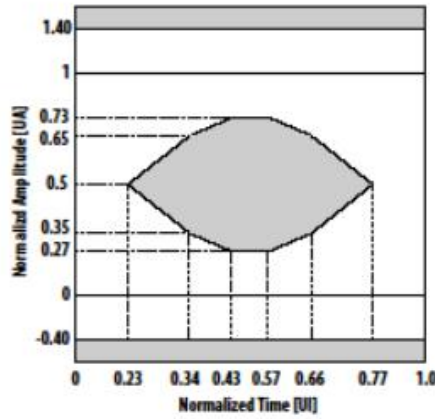

Figure 3. Transmitter eye mask at Hit ratio 5×10^{-5} hits per sample

5.8.QSFP Receiver Optical Specification

Table.8 Receiver Optical Specification

Parameter	Test Point	Min	Typ.	Max	Units	Conditions
Center wavelength	TP3	840	850	860	nm	Each lane
Damage Threshold	TP3	3.4			dBm	Each lane
Average power at receive input	TP3	-9.5		4	dBm	Each lane
Receiver Reflectance	TP3			-12	dB	
Optical Modulation Amplitude	TP3			3	dBm	Each lane
Stressed receiver sensitivity in OMA	TP3			-5.4	dBm	Each lane Measure with conformance test signal for BER 10e-12
Condition of Stressed receiver sensitivity	TP3					
Vertical Eye Closure Penalty	TP3		1.9		dB	Each lane
Stressed eye J2 Jitter	TP3		0.3		UI	Each lane
Stressed eye J9 Jitter	TP3		0.47		UI	Each lane
OMA of each aggressor lane	TP3		-0.4		dBm	

Peak Power	TP3			0	dBm	Each lane
LOS Assert	TP3	-30			dBm	
LOS De-assert OMA	TP3			-7.5	dBm	
LOS Hysteresis	TP3	0.5			dB	

5.9. Recommended QSFP Host Board Power Supply Filtering

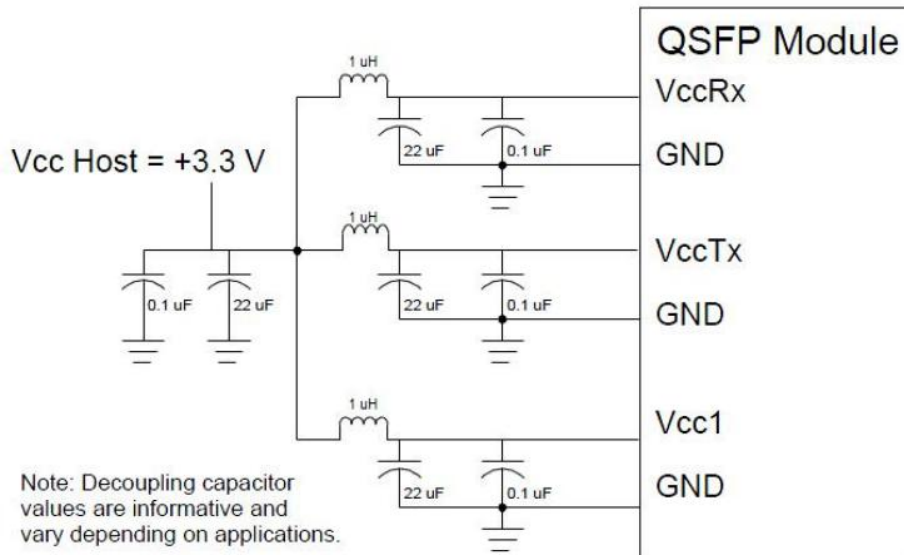

Figure 4: Recommended QSFP Host Board Power Supply Filtering

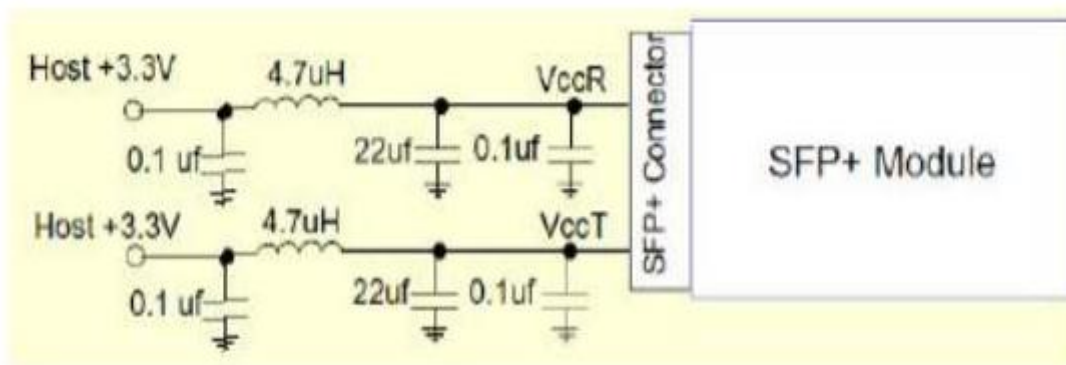

Figure 5: Recommended SFP+ Host Board Power Supply Filtering

5.10.SFP+ Transmitter Optical Specification

Table.9 SFP+ Transmitter Optical Specification

Parameter	Symbol	Min	Typ.	Max	Units	Note
Center wavelength	λ	840	850	860	nm	

RMS spectral width	λ_{RMS}			4	nm	
Average Optical Power	Pavg	-7.3		-1	dBm	1
Optical Power OMA	Poma		-1.5		dBm	
Laser Off Power	Poff			-30	dBm	
Extinction Ratio	ER	3.5			dB	
Transmitter Dispersion Penalty	TDP			3.9	dB	2
Relative Intensity Noise	Rin			-128	dB/HZ	3
Optical Return Loss Tolerance	TP3	20			dB	

5.11.SFP+ Receiver Optical Specification

Table.10 SFP+ Receiver Optical Specification

Parameter	Symbol	Min	Typ.	Max	Units	Note
Center wavelength	λ	840	850	860	nm	
Receiver Sensitivity(OMA)	Sen			-11.1	nm	
Stressed Sensitivity(OMA)	Sen _{ST}			-7.5	dBm	
Los Assert	LOSA	-30			dBm	
Los Dessert	LOSD			-12	dBm	
Los Hysteresis	LOSH	0.5			dB	
Overload	Sat	0			dB	
Receiver Reflectance	Rrx			-12	dB/HZ	

5.12. QSFP Pin Definitions

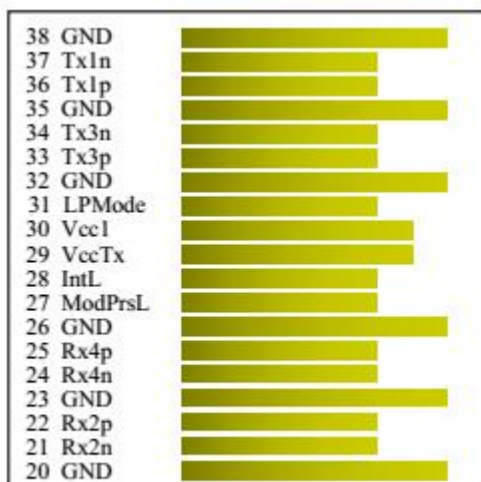

Top Side (Viewed From Top)

Module Card Edge

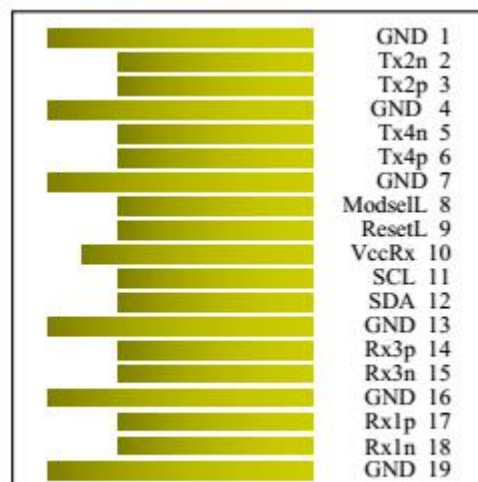

Bottom Side (Viewed From Bottom)

Table.11 QSFP Pin Definitions

Pin number	Logic	Symbol	Signal	Description
1		GND	Signal Ground	Ground
2	CML-I	Tx2n	Tx2n	Transmitter Inverted Date Input.AC coupled
3	CML-I	Tx2p	Tx2p	Transmitter Non_Inverted Date Input.AC coupled
4		GND	Signal Ground	Ground
5	CML-I	Tx4n	Tx4n	Transmitter Inverted Date Input.AC coupled
6	CML-I	Tx4p	Tx4p	Transmitter Non_Inverted Date Input.AC coupled
7		GND	Signal Ground	Ground
8	LVTTTL-I	ModSell	ModSell	Module Select pin.Selected when held low by the host.
9	LVTTTL-I	ResetL	LPMoDe_Reset	Module Reset.A"low" pulse induces a reset on the module.
10		Vcc Rx	Vcc Rx	+3.3V Power Supply Receiver
11	LVC MOS-I/O	SCL	SCL	2-wire serial interface
12	LVC MOS-I/O	SDA	SDA	
13		GND	Signal Ground	Ground
14	CML-O	Rx3p	Rx3p	Receiver Non_Inverted Date Input.AC coupled
15	CML-O	Rx3n	Rx3n	Receiver Inverted Date Input.AC coupled
16		GND	Signal Ground	Ground
17	CML-O	Rx1p	Rx1p	Receiver Non_Inverted Date Input.AC coupled
18	CML-O	Rx1n	Rx1n	Receiver Inverted Date Input.AC coupled
19		GND	Signal Ground	Ground
20		GND	Signal Ground	Ground
21	CML-O	Rx2n	Rx2n	Receiver Inverted Date Input.AC coupled
22	CML-O	Rx2p	Rx2p	Receiver Non_Inverted Date Input.AC coupled
23		GND	Signal Ground	Ground
24	CML-O	Rx4n	Rx4n	Receiver Inverted Date Input.AC coupled
25	CML-O	Rx4p	Rx4p	Receiver Non_Inverted Date Input.AC coupled
26		GND	Signal Ground	Ground
27	LVTTTL-O	ModPrsL	ModPrsL	Module Present pin.Internally grounded inside the module.
28	LVTTTL-O	IntL	IntL	Interrupt by the QSFP module."Low"indicates an Alarm/Warning.
29		Vcc Tx	Vcc Tx	+3.3V Power Supply Transmitter
30		Vccl	Vccl	+3.3V Power Supply
31	LVTTTL-I	LPMoDe	LPMoDe	Low Power Mode
32		GND	Signal Ground	Ground
33	CML-I	Tx3p	Tx3p	Transmitter Non_Inverted Date Input.AC coupled
34	CML-I	Tx3n	Tx3n	Transmitter Inverted Date Input.AC coupled
35		GND	Signal Ground	Ground
36	CML-I	Tx1p	Tx1p	Transmitter Non_Inverted Date Input.AC coupled
37	CML-I	Tx1n	Tx1n	Transmitter Inverted Date Input.AC coupled
38		GND	Signal Ground	Ground
Housing			Chassis Ground	

5.13. SFP+ Pin Definitions

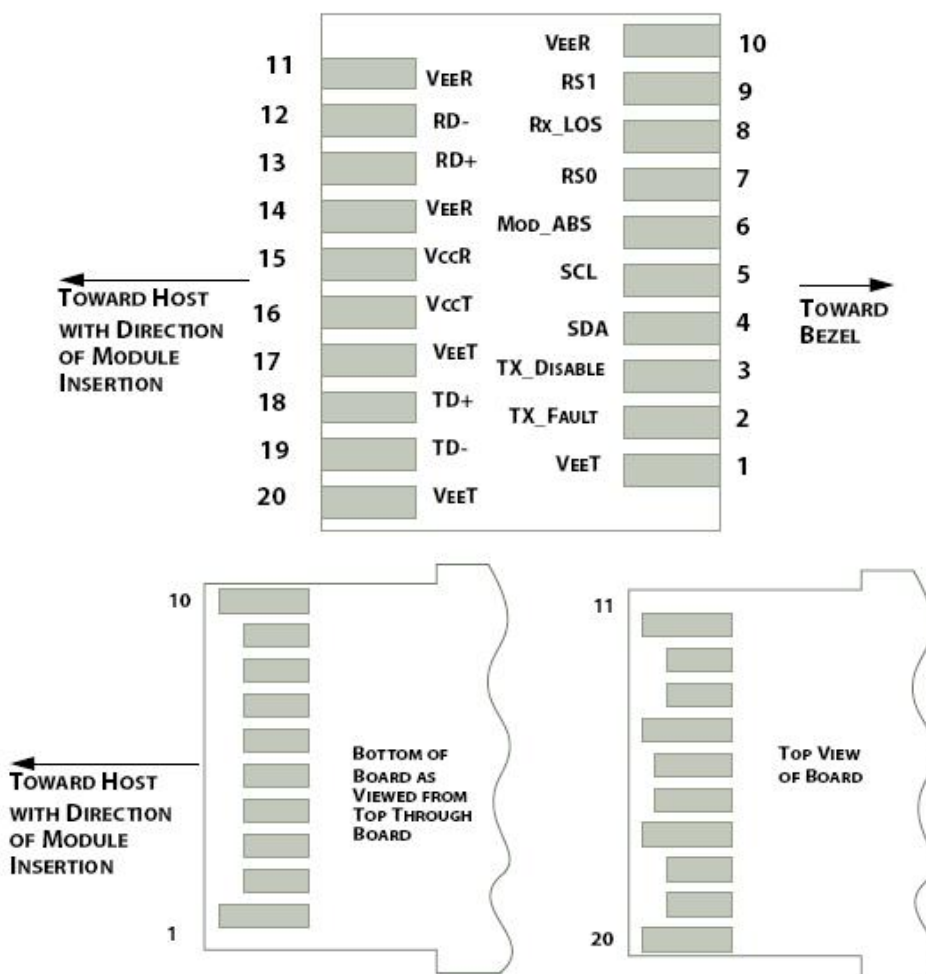

Table.12 SFP+ Pin Definitions

PIN	Description	Remarks
1	Transmitter ground (common with receiver ground)	Circuit ground is isolated from chassis ground
2	Transmitter Fault. Not supported	
3	Transmitter Disable. Laser output disable on high or open	Disabled: TDIS>2V or open Enabled: TDIS<0.8V
4	2-wire Serial Interface Data Line	Should Be pulled up with 4.7k – 10k ohm on host board to a voltage between 2V and 3.6V
5	2-wire Serial Interface Clock Line	
6	Module Absent. Grounded within the module.	
7	No connection required	
8	Loss of Signal indication. Logic 0 indicates normal operation	LOS is open collector output
9	No connection required	
10	Receiver ground (common with transmitter ground)	Circuit ground is isolated from chassis ground

11	Receiver ground (common with transmitter ground)	
12	Receiver Inverted DATA out. AC coupled	
13	Receiver Non-inverted DATA out. AC coupled	
14	Receiver ground (common with transmitter ground)	Circuit ground is isolated from chassis ground
15	Receiver power supply	
16	Transmitter power supply	
17	Transmitter ground (common with receiver ground)	Circuit ground is isolated from chassis ground
18	Transmitter Non-Inverted DATA in. AC coupled	
19	Transmitter Inverted DATA in. AC coupled	
20	Transmitter ground (common with receiver ground)	Circuit ground is isolated from chassis ground

5.14. Mechanical Specifications

Table.13 Mechanical Specifications

Parameter	Min	Max.	Unit	Notes
Cable bend radius(Installation)	30		mm	
Cable bend radius(Operating)	60			
QSFP module insertion		40	N	
QSFP module extraction		30	N	
Retention Load	100		N	No damage to module below 100N
Insertion/removal cycles	200		Cycles	Number of cycles for an individual module

5.15. Functional Block Diagram of the QSFP Module

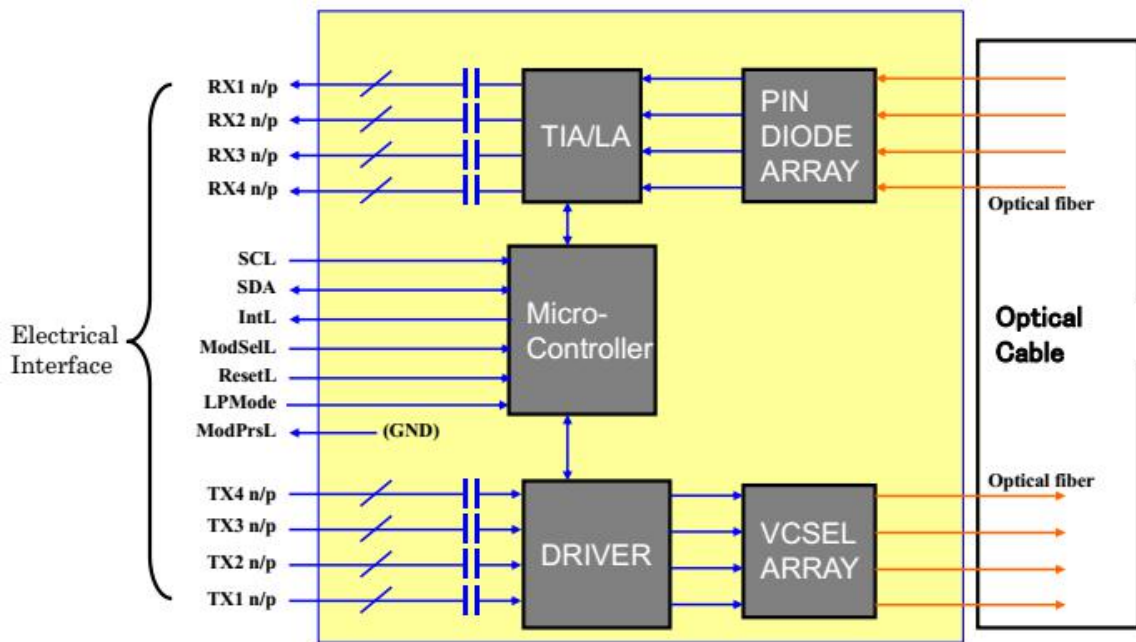
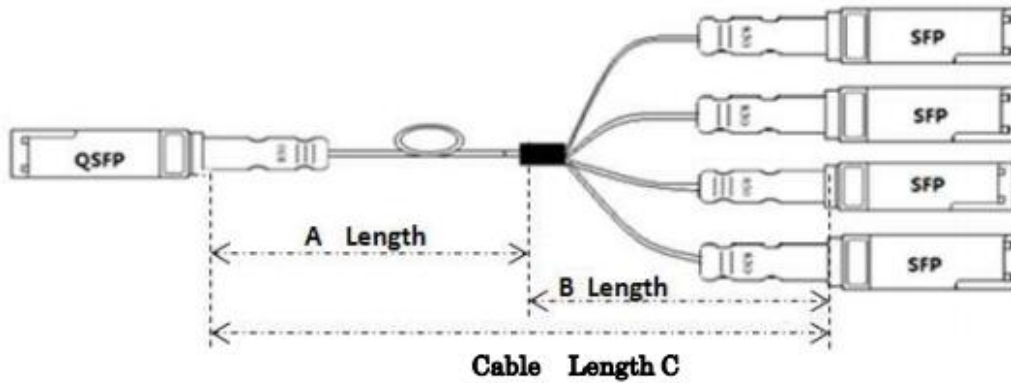

Figure 6:Functional Block Diagram of the QSFP Module

5.16. Overview of Cable Assembly



Cable length(m) C	A length	B length
Cable length(m) C=A+B		
A and B lengths may be available upon request		

Figure 7:Overview of Cable Assembly

6. Application Cautions

6.1. ESD

This transceiver is specified as ESD threshold 1kV for high speed pins and 2kV for all other electrical input pins, tested per MIL-STD-883, Method 3015.4 /JESD22-A114-A (HBM). However, normal ESD precautions are still required during the handling of this module. This transceiver is shipped in ESD protective packaging. It should be removed from the packaging and handled only in an ESD protected environment.

6.2. LASER SAFTY

This is a Class 1 Laser Product according to IEC 60825-1:1993:+A1:1997+A2:2001. This product complies with 21 CFR 1040.10 and 1040.11 except for deviations pursuant to Laser Notice No. 50, dated (July 26, 2001)

7. Order Information

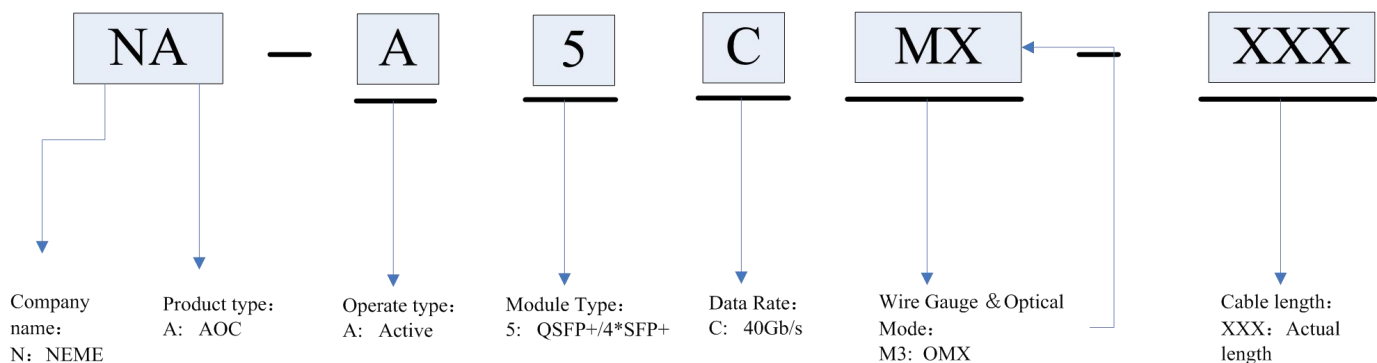

Further Information

For further information, please contact NEME.

Tel: 0086-400-966-4008

Fax: 0086-0755-86152561

Web: www.nemengine.com

Add: 3/F, 20th Bldg. Guangqian Ind Zone. No.3 Longzhu Rd. Nanshan Dist. S.Z City, CHINA.

Shenzhen NEM Engine Technology Co., Ltd.

Tel: 0086-400-966-4008

Fax: 0086-0755-86152561

E-mail: info@nemengine.com

Web: www.nemengine.com